

Diagnosing Faults in Photovoltaic Arrays through Smart Grid: A Novel Approach

Dr V MADHU SUDANAREDDY ¹, RAMRAJSINGH PRATHAP SINGH ²

Assistant professor^{1,2}

DEPARTMENT OF ELECTRONICS AND COMMUNICATION ENGINEERING

P.B.R.VISVODAYA INSTITUTE OF TECHNOLOGY & SCIENCE

S.P.S.R NELLORE DIST, A.P , INDIA , KAVALI-524201

Abstract

In this research, a novel approach to defect diagnosis for PV arrays with SP connection is provided, with the potential benefits of reducing the total number of sensors required while simultaneously enhancing accuracy and anti-interference capacity via the use of fuzzy group decision-making theory. We evaluated voltage, current, ambient temperature, panel temperature, and solar illumination as five "decision makers" that aid in PV array defect diagnostics. Experimental verification of the proposed method's accuracy and reliability and an analysis of the potential variables leading to diagnostic deviation led to the development of recommendations for minimizing or eradicating mistakes in the software and hardware components.

Introduction

To maximize output and service life, photovoltaic (PV) arrays should run consistently and reliably. Nonetheless, PV arrays are prone to a wide range of issues, including hot spots, aging, and corrosion [1, 2], which may drastically limit power production or even permanently destroy the batteries [1, 3]. Therefore, finding and fixing these issues in PV arrays is crucial. Infrared image-based approaches and electrical signal-based methods both play a role in PV array fault diagnostics. The former technique takes use of the fact that there is a distinct temperature differential between the defective and nondefective PV arrays, which can be seen in infrared pictures [2, 4]. However, it has been criticized for its lack of precision, the fragility of the equipment it employs, and the length of time it takes to respond. Despite years of investment in improving hardware and software, large-scale PV array failure diagnostics has not advanced much in recent years. However, despite drawbacks such the need for a large number of sensors, a lack of precision, an inability to scale to large PV arrays, and susceptibility to external impacts, the electrical approach has found a place in problem diagnostics. The high frequency response measurement with time domain analysis offered by Japanese academics [5, 6] for the identification of faulty modules was an electrical technique with no real-time property and a low practical potential of functioning. Despite these limitations, faults may be detected and localized

using voltage or current sensors in the majority of fault detection approaches [5, 7–11]. Previously, researchers have developed a novel PV connection for defect detection in large-scale PV systems by embedding several sensors and using a "data fusion" approach [7]. Alternatively, solar PV module branches might be connected to the solar adaptive bank through a switching matrix [8]. The shunt resistance, series resistance, and diode factor of PV modules have all been demonstrated to have strong correlations with PV array defects [9]. In order to obtain the I-V curves of PV module strings, a unique approach was presented; failures were then identified using parameter shifts based on the I-V curves. Fault detection in PV module strings was described using two techniques: electrical capacitance measurement (ECM) and time-domain reflectometry (TDR) [5]. TDR could identify the degradation position (series resistance rise) by the change of response waveform, whereas ECM could detect the disconnection location in the string independently of irradiance variation. These methods still suffer from the drawbacks mentioned before. Furthermore, present PV inverter fault diagnostic functions can only report branch faults.

A Novel Approach to PV Array Fault Diagnosis

Detection Structure for Sensors and PV Array Connections

the framework for connecting PV arrays, also known as

There is a maximum voltage and current that can be produced by a single PV cell. Connecting cells in series, parallel, series-parallel (SP), or total cross-tied (TCT) forms bigger arrays, which increases voltage and current output [19]. Monitoring large-scale PV arrays requires taking into account the impact of connection structure and detection method of voltage and current sensors. Different detection structures based on various network architectures have been presented. For instance, PV arrays may have integrated sensors connected by TCT.

However, such buildings are often expensive and difficult to construct.

A Redesigned System for Sensor Detection.

The ideal detection structure would (1) need as few sensors as feasible, (2) have a high resolution, and (3) be flexible enough to work with large-scale PV arrays. As illustrated in Figure 1, this research proposes a detection framework that meets the aforementioned criteria. There are three sensors (one current sensor and two voltage sensors) concealed inside each branch of this detecting structure, which is based on a 4 by 8 PV array with SP connection. This means that if one solar panel fails, only the two surrounding panels will be affected.

$$\text{If } I_i < I_j, (0 < i \leq 4, 0 < j \leq 4 \text{ and } j \neq i),$$

fault occurs in the i -th branch. Then the failed panel can be located according to the voltages measured by the two voltage sensors. There are four possibilities (PV panels are numbered from top to bottom).

- (1) If No.1 or No.2 panel fails, then $V_{i1} < V_{j1}, V_{i2} > V_{j2}$, where $1 \leq j \leq 4$ and $j \neq i$;
- (2) If No.3 or No.4 panel fails, then $V_{i1} < V_{j1}, V_{i2} < V_{j2}$, where $1 \leq j \leq 4$ and $j \neq i$;

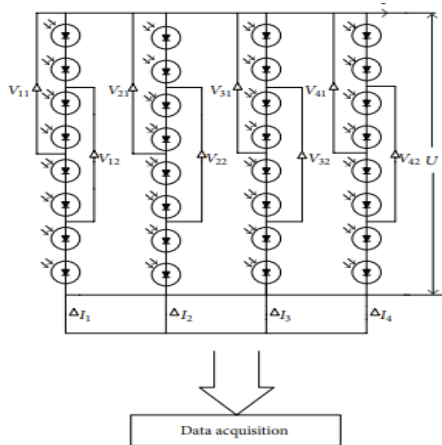

Figure 1: A new fault detection structure.

- (3) If No.5 or No.6 panel fails, then $V_{i1} > V_{j1}, V_{i2} < V_{j2}$, where $1 \leq j \leq 4$ and $j \neq i$;
- (4) If No.7 or No.8 panel fails, then $V_{i1} > V_{j1}, V_{i2} > V_{j2}$, where $1 \leq j \leq 4$ and $j \neq i$;

For the detection structure of $M \times N$ PV array (N branches, M solar panels in each branch) shown in Figure 2, the resolution of fault location is assumed to be L (accordingly, one voltage sensor is responsible for $2 \times L$ solar panels) and each branch has p voltage sensors. Fault will be located based on

the voltage and current data collected by a microcontroller.

(a) If

$$\begin{aligned} V_{hr} &< V_{ij}, (0 < i \leq N, i \neq h, 0 < j \leq p) \\ V_{hs} &> V_{ij}, (0 < s \leq p, s \neq r, 0 < i \leq N, i \neq h, 0 < j \leq p) \\ V_{ij} &= V_{uv}, (0 < i, j, u, v \leq N; i, j, u, v \neq h), \end{aligned}$$

fault occurs in No. h branch due to different sensor readings in this branch. Then it can be determined that the failed panel is within the range of the r -th sensor.

(b) If

$$\begin{aligned} V_{hr} &< V_{ij}, V_{h(r+1)} < V_{ij}, (0 < i \leq N, i \neq h, 0 < j \leq p) \\ V_{hs} &> V_{ij}, (0 < s \leq p, s \neq r, s \neq r + 1, 0 < i \leq N, i \neq h, 0 < j \leq p) \\ V_{ij} &= V_{uv}, (0 < i, j, u, v \leq N; i, j, u, v \neq h), \end{aligned}$$

fault occurs in No. h branch due to different sensor readings in this branch. Then it can be determined that the failed panel is within the cross range of No. r and No. $(r+1)$ sensor.

Experiment and Analysis

Experiment Design and Data Analysis.

Figure 4 depicts the results of experimental confirmation of the suggested technique using bespoke PV panels. Each PV monomer has its own connections, allowing for flexible wiring. It has four forks, labeled 1 through 4. The DS18B20 digital thermometer is used to monitor temperature, while the TI TSL230B light to frequency converter is used to detect solar irradiance. In Table 1, V11–V42 represent voltages, I1–I4 represent currents, Te1–Te4 represent ambient temperatures, Tp1–Tp4 represent panel temperatures, and G1–G4 represent solar irradiances. Since PV array problems are not directly influenced by either ambient temperature or solar irradiation, a unique treatment is used. All preference values are normalized to a value of 0.2, and rank results are computed using either $r(I)k$ or $r(V)k$. The failure probability drops, VL and Lare go up, and M, H, and VH go down when they are abnormal. Using a cross-triangular membership function, the four people involved in the decision-making process engage in a fuzzy quantitative analysis. Table 2 displays the No. 1 location's preferences. Table 3 displays the ranks as they were determined. Table 4 displays the findings for the standard generalized distance Q_{ij} , computed using formula (13), for the values of $\alpha = 0.7$, $\beta = 0.3$, $QA = 0.05$, and $QD = 0.5$. When looking at Table 5's evaluation indices, we can see that the overall consistency index is 0.20, while the divergence index is 0.,

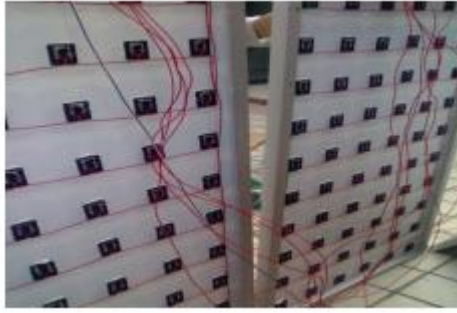

Figure 4: Custom-made solar panels.

indicating a high consistency between decision makers. Therefore, No.1 branch has a relatively high probability of faults. According to the judgment process described above, No.1 or No.2 PV cell in the first branch might fail. By following the same process as above, we found that No.2 and No.3 branch have no fault, but No.4 branch has fault. The remarkable consistency is 0.10 and the serious divergence is 0.60, indicating a false fault detection. The deviation of the voltage and current from normal range may be due to environmental factors. A miscarriage of justice would happen if the decision is made on the basis of incomplete measurement data rather on group decision making in which a group of decision makers work collectively to find the best candidate from a set of alternatives.

Errors and Solutions.

The precision of the system would decrease due to the errors inherent in measurement and data processing. It is necessary to analyze these errors and provide solutions to improve the effectiveness of the system [16].

Voltage and Current Sensors.

Hall current and voltage sensors are used in this study. Without considering the effect of temperature, the output voltage (UV) and current (UI) of Hall sensors are

$$U_V = \alpha V,$$

$$U_I = \beta I,$$

where V and I are the measured voltage and current and α and β are constants, respectively. When temperature is taken into account

$$U_V = f(V, T),$$

$$U_I = g(I, T).$$

Since f and g are unknown functions, each depending on two variables, two-dimensional regression analysis is used to determine the relationship between the measured parameters and sensor outputs. Then the coefficients of the regression equation are calculated using the least square method. The two-dimensional regression equation is established based on (16):

$$I = \bar{g}(U_V, T).$$

Table 1: Data collected by experimental system

Branch	1		2		3		4	
	V_{n1}	V_{n2}	V_{21}	V_{22}	V_{31}	V_{32}	V_{41}	V_{42}
Voltage (V)	1.559	2.454	2.072	2.086	2.060	2.074	1.876	2.190
	I_1	I_2	I_3	I_4				
Current (A)	0.041	0.128	0.121	0.081				
	T_{e1}	T_{e2}	T_{e3}	T_{e4}				
Environmental temperature (°C)	24.2	24.2	24.2	24.0				
	T_{p1}	T_{p2}	T_{p3}	T_{p4}				
Panel temperature (°C)	38.1	37.4	37.5	31.9				
	G_1	G_2	G_3	G_4				
Solar irradiance (W/m^2)	760	762	760	410				

Table 2: Preference of different decision makers.

Decision makers	Preference				
	VL	L	M	H	VH
d_V	0.00	0.00	0.00	0.00	1.00
d_I	0.00	0.00	0.00	0.65	0.35
d_{TE}	0.20	0.20	0.20	0.20	0.20
d_{TP}	0.00	0.00	0.00	0.80	0.20
d_G	0.20	0.20	0.20	0.20	0.20

Table 3: Ranks of preference

Decision makers	Ranks				
	VL	L	M	H	VH
d_V	5	4	3	2	1
d_I	5	4	3	1	2
d_{TE}	5	4	3	2	1
d_{TP}	5	4	3	1	2
d_G	5	4	3	2	1

Table 4: Weighted generalized distance

Q_j	d_V	d_I	d_{TE}	d_{TP}	d_G
d_V	0.00	0.21	0.21	0.25	0.21
d_I	0.21	0.00	0.18	0.05	0.18
d_{TE}	0.21	0.18	0.00	0.19	0.00
d_{TP}	0.25	0.05	0.19	0.00	0.19
d_G	0.21	0.18	0.00	0.19	0.00

Table 5: Software evaluation indexes

Decision makers	IAI	IDI
d_V	0.00	0.00
d_I	0.25	0.00
d_{TE}	0.25	0.00
d_{TP}	0.25	0.00
d_G	0.25	0.00
Combined index	0.20	0.00

Conclusions

With the introduction of fuzzy group decision-making theory, this research proposes a new fault diagnosis method for PV arrays with SP connection that has practical application value and can reduce the overall number of sensors, cost, and improve accuracy and anti-interference ability. Accurate failure detection of PV arrays is achieved by effectively using data on voltage, current, ambient temperature, panel temperature, and solar illumination. Furthermore, the causes of diagnostic mistake are discussed, and strategies to increase diagnostic accuracy are proposed..

References

- [1] A. M. Bazzi, K. A. Kim, B. B. Johnson, P. T. Krein, and A. Dominguez-Garcia, "Fault impacts on solar power unit reliability," in *Proceedings of the 26th Annual IEEE Applied Power Electronics Conference and Exposition (APEC '11)*, pp. 1223–1231, Fort Worth, Tex, USA, March 2011.
- [2] F. Ancuta and C. Cepisca, "Fault analysis possibilities for PV panels," in *Proceedings of the 3rd International Youth Conference on Energetics (IYCE '11)*, pp. 1–5, Leiria, Portugal, July 2011.
- [3] A. Colli, "Extending performance and evaluating risks of PV systems failure using a fault tree and event tree approach: analysis of the possible application," in *Proceedings of the 38th IEEE Photovoltaic Specialists Conference (PVSC '12)*, pp. 2922–2926, Austin, Tex, USA, June 2012.
- [4] H. Braun, S. T. Buddha, V. Krishnan et al., "Signal processing for fault detection in photovoltaic arrays," in *Proceedings of the IEEE International Conference on Acoustics, Speech, and Signal Processing (ICASSP '12)*, pp. 1681–1684, March 2012.
- [5] T. Takashima, J. Yamaguchi, K. Otani, T. Oozeki, K. Kato, and M. Ishida, "Experimental studies of fault location in PV module strings," *Solar Energy Materials and Solar Cells*, vol. 93, no. 6-7, pp. 1079–1082, 2009.
- [6] T. Takashima, K. Otani, K. Sakuta et al., "Electrical detection and specification of failed modules in PV array," in *Proceedings of the 3rd World Conference on Photovoltaic Energy Conversion*, vol. 3, pp. 2276–2279, May 2003.
- [7] Z. Cheng, D. Zhong, B. Li, and Y. Liu, "Research on fault detection of PV array based on data fusion and fuzzy mathematics," in *Proceedings of the Asia-Pacific Power and Energy Engineering Conference (APPEEC '11)*, pp. 1–4, Wuhan, China, March 2011.
- [8] D. Nguyen and B. Lehman, "An adaptive solar photovoltaic array using model-based reconfiguration algorithm," *IEEE Transactions on Industrial Electronics*, vol. 55, no. 7, pp. 2644–2654, 2008.
- [9] Y. Hirata, S. Noro, T. Aoki, and S. Miyazawa, "Diagnosis photovoltaic failure by simple function method to acquire I-V curve of photovoltaic modules string," in *Proceedings of the 38th IEEE Photovoltaic Specialists Conference (PVSC '12)*, pp. 1340–1343, June 2012.
- [10] D. Chenvidhya, K. Kirtikara, and C. Jivocate, "PV module dynamic impedance and its voltage and frequency dependencies," *Solar Energy Materials and Solar Cells*, vol. 86, no. 2, pp. 243–251, 2005.
- [11] H. Braun, S. T. Buddha, V. Krishnan et al., "Signal processing for fault detection in photovoltaic arrays," in *Proceeding of the IEEE International Conference on Acoustics, Speech, and Signal Processing (ICASSP '12)*, pp. 1681–1684, Kyoto, Japan, March 2012.
- [12] X.-Q. Liu, X. Chen, and H. Zhang, "A multi-character group decision-making method and application based on group ideal solution," *Journal of Shenyang Institute of Aeronautical Engineering*, vol. 24, no. 2, pp. 38–41, 2007 (Chinese).
- [13] Y. He, F. Chu, and B. Zhong, "A study on group decision-making based fault multi-symptom-domain consensus diagnosis," *Reliability Engineering and System Safety*, vol. 74, no. 1, pp. 43–52, 2001.
- [14] Y. Lai, X. Li, Y. Xiong, P. Du, and B. Lu, "Intelligent instrument fault diagnosis expert system based on fuzzy group decisionmaking," *Chinese Journal of Scientific Instrument*, vol. 29, no. 1, pp. 206–211, 2008 (Chinese).
- [15] J. Wang and J. Ren, "Approach to group decision-making with different forms of preference information," *Systems Engineering and Electronics*, vol. 27, no. 12, pp. 2057–2060, 2005.
- [16] J. Jiang, Y. Chen, and D. Tang, "TOPSIS with belief structure for group belief multiple criteria decision making," *International Journal of Automation and Computing*, vol. 7, no. 3, pp. 359–364, 2010.
- [17] G. Yan, C. Liu, and Z. Shao, "Analysis of influencing factors for the grey multi-attribute group decision making," in *Proceedings of the IEEE International Conference on Grey Systems and Intelligent Services (GSIS '09)*, vol. 10, pp. 1081–1086, Nanjing, China, November 2009. [18] Y. Liu, "Design of a new moisture sensor with auto temperature compensation," *Journal of Zhejiang University*, vol. 33, pp. 427–431, 1999.
- [19] Y. Liu, Z. Pang, and Z. Cheng, "Research on an adaptive solar photovoltaic array using shading degree model-based reconfiguration algorithm," in *Proceedings of the Chinese Control and Decision Conference (CCDC '10)*, pp. 2356–2360, May 2010.
- [20] X. G. Wang and W. Liu, "A fuzzy fault diagnosis scheme with application," in *Proceedings of the Joint 9th IFSA World Congress and 20th NAFIPS International Conference*, vol. 3, pp. 1489–1493, Vancouver, Canada, July 200.